

COLUMN SPEAKER(OUTDOOR USE)



FEATURES

- **OUTDOOR USE**
These column speakers are designed for outdoor use.
- **LONG LIFE**
You can use these long time, why these are designed with aluminum alloy and painted for anti-rust.
- **HIGH EFFICIENCY FOR P.A.**
Full range speaker unit and matching transformer are incorporated for high efficiency of P.A.
- **EASY INSTALLATION**
With instrument, you can install it easily by using provided bracket.
- **2 WAY SYSTEM**
To assure absolute long-term reliability, these model are used by tweeter of high quality.

SPECIFICATION

- **ELECTRICAL** * 0dB=0.775Vrms
 - Rated input20W
 - Impedance 500Ω/1kΩ
 - Frequency response200Hz-22kHz
 - SPL(1W/1m)96dB
- **GENERAL**
 - Material of caseAluminum
 - Weight3.6kg
 - Dimensions 149(W)×420(H)×124(D)mm

MOUNTING METHOD

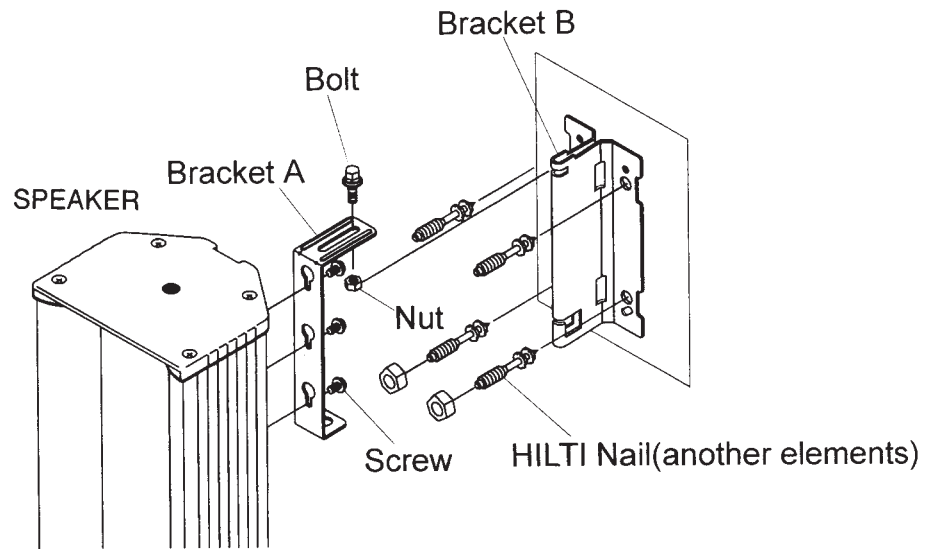

DUAL CHANNEL ANALYZER GRAPHICS

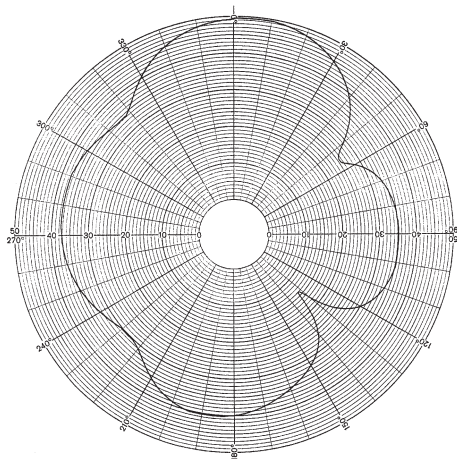

Horizontal

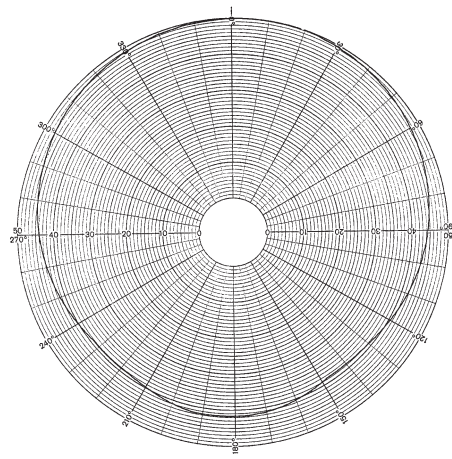

Vertical

